



**LB-60-80
LOAD BANK**

**MANUAL CONTAINS
OPERATING INSTRUCTIONS
PARTS LIST
WIRING DIAGRAMS
SERVICE INSTRUCTIONS**

**Eagle Eye Power Solutions, LLC.
4230 N. Oakland Ave.
Milwaukee, WI 53211**

CAUTION

THIS LOAD BANK IS DESIGNED FOR THE TESTING AND SERVICING 480/208V 60HZ POWER UNITS. THESE UNITS HAVE THE POTENTIAL OF DELIVERING A LETHAL SHOCK. THIS LOAD BANK SHOULD BE USED ONLY BY TRAINED AND QUALIFIED PERSONNEL. THIS LOAD BANK IS DESIGNED FOR TEMPORARY USE ONLY. THE LOAD RESISTORS ARE ENERGIZED WHEN THE RATE SWITCH IS OFF, THEREFORE DO NOT INSERT ANY OBJECTS IN THE GRILL ASSEMBLY. DO NOT BLOCK THE AIR FLOW OR USE IF THE AIR FLOW IS REVERSED.

MANUAL FOR LB-60-80 LOAD BANK

TABLE OF CONTENTS

<u>SUBJECT</u>		<u>SECTION</u>	<u>PAGE</u>
DESCRIPTION			
PURPOSE OF LOAD BANK		1 - 1	1
RATING OF LOAD BANK		1 - 2	1
LOAD BANK DESCRIPTION	FIGURE 1 - 1	1 - 3	1
CONTROL PANEL LAYOUT	FIGURE 1 - 2	1	2
CONTROL DESCRIPTION		1 - 4	3
OPERATION			
TESTING 120VAC SINGLE PHASE		2	1
TESTING 240VAC SINGLE PHASE		2	3
TESTING 208VAC THREE PHASE		2	5
TESTING 240VAC THREE PHASE		2	7
TESTING 480VAC THREE PHASE		2	9
PARTS			
PARTS INFORMATION		3	1
CONTROL PANEL PARTS LAYOUT	FIGURE 3 - 1	3	2
CONTROL PANEL PARTS LIST		3	3
INTERIOR PARTS LAYOUT	FIGURE 3 - 2	3	4
INTERIOR PARTS LIST		3	5
FAN PANEL PARTS LAYOUT	FIGURE 3 - 3	3	6
FAN PANEL PARTS LIST		3	7
VENDOR LIST		3	8
SERVICING			
GENERAL SERVICING		4 - 1	1
REPLACING FAN	FIGURE 4 - 1	4 - 2	2
WIRING DIAGRAMS			
INTERIOR WIRING	FIGURE 5 - 1	5	1
FAN PANEL WIRING	FIGURE 5 - 2	5	3
SCHEMATIC DIAGRAM	FIGURE 5 - 3	5	5

DESCRIPTION

1-1 PURPOSE OF LOAD BANK: The LB-60-80 is a portable load bank designed to be used for field servicing and testing 60HZ generators and UPS systems. It can be used for checking cables after they have been replaced or repaired. The load bank can also be shipped to different locations using the carrying case.

1-2 RATING OF LOAD BANK: The LB-60-80 is rated at 100 KW full load when the input voltage is 480VAC and 80 KW when the input voltage is 208VAC with all five load steps turned on. The load steps are 12.5KW, 12.5KW, 25KW, 25KW and 25KW at 480VAC, 10KW, 10KW, 20KW, 20KW, 20KW at 208VAC. All steps are continuous.

1-3 LOAD BANK DESCRIPTION: The load bank is uses a 120VAC power source to operate other than the power being tested. The different sides of the load bank are shown in fig. 1-1. The air enters the right side (fan side) and exits the left side.

<<<< AIR FLOW <<<<

LEFT SIDE



RIGHT SIDE (FAN SIDE)

LENGTH 22 IN.
WIDTH 8 IN.
HEIGHT 21 IN.
WEIGH 60 LBS.

CONTROL PANEL PARTS

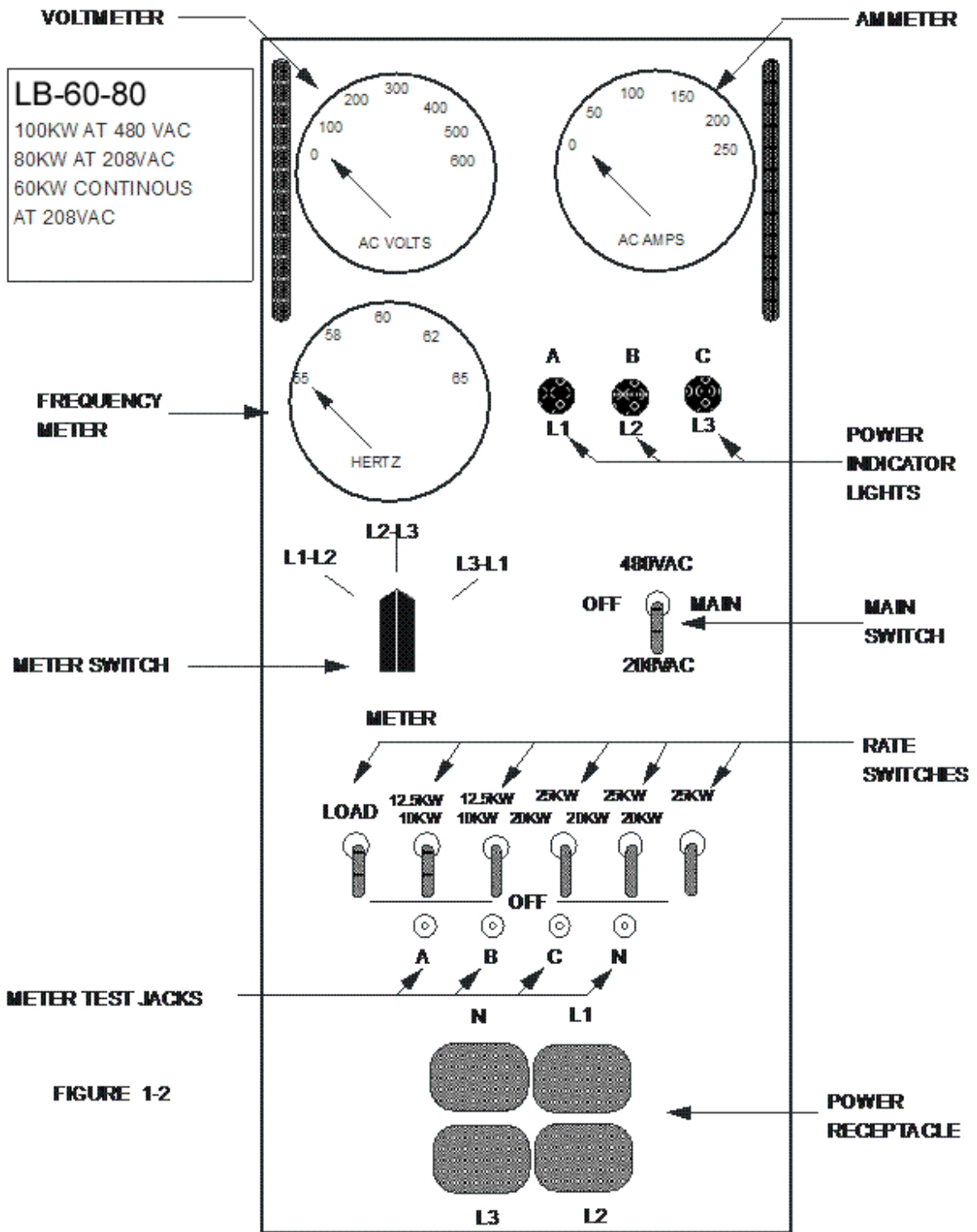

FIGURE 1-2

FIGURE 1-1

1-4 CONTROL DESCRIPTION: The following is a description of the controls on the control panel (see figure 1-2 on page 2).

VOLT METER - A 600 volt meter used to measure the line to line voltage on the power cable. L1-L2, L2-L3, L3-L1 can be selected using the meter selector switch. The meter should read approximately 480 volts when testing 480VAC systems, and 208VAC when testing 208VAC systems.

AMMETER - A 250 amp ammeter used to measure the load being used by the load bank. It monitors "A" phase.

FREQUENCY METER - A 55-65 HZ meter used to measure the frequency of the power unit. It should read approximately 60HZ.

METER SWITCH - Switch used to select L1-L2, L2-L3, and L3-L1 on the voltmeter.

RATE SWITCHES - Switch used to select the desired rate on the load bank. The rates are as follows:

480VAC		208VAC	
1.	12.5 KW balanced load	1.	10 KW balanced load
2.	12.5 KW balanced load	2.	10 KW balanced load
3.	25 KW balanced load	3.	20 KW balanced load
4.	25 KW balanced load	4.	20 KW balanced load
5.	25 KW balanced load	5.	20 KW balanced load

POWER INDICATOR LIGHTS - These lights will light to indicate power on A, B, and C phase. All three lights should be on when testing three phase circuits.

METER TEST JACKS - This provides a place to connect an external meter. There is a test jack for each cable pin.

POWER RECEPTACLE - The power cable from the equipment to be tested is plugged into the load bank through the receptacle.

120 VOLT POWER RECEPTACLE - A power cable is provided to plug the unit into a 120VAC outlet.
(Not shown on drawing)

OPERATION

TESTING 120VAC SINGLE PHASE

2-1 SETTING UP THE LOAD BANK - Place the load bank in an area free from fuel, oil, or any other flammable substance. The load bank should be positioned so that any strong wind or air currents will flow with the air flow of the load bank.

2-2 APPLYING POWER - The load bank should be connected to the power unit to be tested with an output of 120VAC single phase. Make sure that the power unit is off before connecting the cable to the load bank. Use L1, L2 and N, the blue and yellow plug, when testing single phase circuits. L1 should be connected to the line out, L2 should be connected to neutral and the N cable with the green shrink should be connected to the ground of the unit being tested. **Make sure the lug on L3 is insulated.** Plug the power cable plug in to the load bank. The meter switch should be in the L1-L2 position. Turn on the output of the power unit.

2-3 CHECKING THE POWER - check the following:

- A. The amber light, "A" should be on.
- B. The voltmeter should read 120VAC on "A" phase.
- C. The frequency meter should read approximately 60HZ.
- D. The ammeter should read 0A.

2-4 APPLYING THE LOAD - If the above steps checked OK, turn on the main switch to 208VAC. The fans should start up and the airflow should be as indicated by the airflow arrow. Next turn on the load switch. Add the load desired with the rate switch.

- A. Step 1 is 1.7KW
- B. Step 2 is 1.7KW
- C. Step 3 is 3.3KW
- D. Step 4 is 3.3KW
- E. Step 5 is 3.3KW

Total load at 120VAC is 13.3KW.

Check to see that the voltage and frequency does not drop beyond acceptable limits under load.

2-5 SHUTTING DOWN - Turn the load switch and rate switches to the off position and allow the load bank to cool down before turning the main switch to off. Turn the power unit off and disconnect the power cable plug.

OPERATION

TESTING 208VAC THREE PHASE

2-1 SETTING UP THE LOAD BANK - Place the load bank in an area free from fuel, oil, or any other flammable substance. The load bank should be positioned so that any strong wind or air currents will flow with the air flow of the load bank.

2-2 APPLYING POWER - The load bank should be connected to the power unit to be tested with an output of 208VAC 3 phase, plug in the 120VAC power cord. Make sure that the main switch and the load switch is set to off before connecting the cable to the load bank. Use L1, L2, L3 and N, the blue and red plug, when testing 208VAC 3 phase circuits. Plug the power cable plug in to the load bank. Turn on the output of the power unit.

2-3 CHECKING THE POWER - check the following:

- A. The amber light, "A", "B", "C" should be on.
- B. The voltmeter should read 208VAC.
- C. The frequency meter should read approximately 60HZ.
- D. The ammeter should read 0A.

2-4 APPLYING THE LOAD - If the above steps checked OK, turn the main switch to 208VAC. The fans should start up and the airflow should be as indicated by the airflow arrow. Next turn on the load switch. Add the load desired with the rate switch.

- A. Step 1 is 10 KW
- B. Step 2 is 10 KW
- C. Step 3 is 20 KW
- D. Step 4 is 20 KW
- E. Step 5 is 20 KW

THIS UNIT SHOULD NOT BE RUN FOR MORE THAN ONE HOUR CONTINUOUS AT 208VAC, 80KW. THE RECEPTACLE IS RATED ONLY AT 63KW FOR CONTINUOUS RUNNING.

Check to see that the voltage and frequency does not drop beyond acceptable limits under load. Return the rate switch to the off position.

2-5 SHUTTING DOWN - Return the load and rate switches to the off position and, allow the load bank to cool down before turning the power unit off. Turn the power unit off and disconnect the power cable plug.

TESTING 240VAC THREE PHASE

2-1 SETTING UP THE LOAD BANK - Place the load bank in an area free from fuel, oil, or any other flammable substance. The load bank should be positioned so that any strong wind or air currents will flow with the air flow of the load bank.

2-2 APPLYING POWER - The load bank should be connected to the power unit to be tested with an output of 240VAC 3 phase, plug in the 120VAC power cord. Make sure that the main switch and the load switch is set to off before connecting the cable to the load bank. Use L1, L2, L3 and N, the blue and red plug, when testing 240VAC 3 phase circuits. Plug the power cable plug in to the load bank. Turn on the output of the power unit.

2-3 CHECKING THE POWER - check the following:

- A. The amber light, "A", "B", "C" should be on.
- B. The voltmeter should read 240VAC.
- C. The frequency meter should read approximately 60HZ.
- D. The ammeter should read 0A.

2-4 APPLYING THE LOAD - If the above steps checked OK, turn the main switch to 208VAC. The fans should start up and the airflow should be as indicated by the airflow arrow. Next turn on the load switch. Add the load desired with the rate switch.

- A. Step 1 is 12.5 KW
- B. Step 2 is 12.5 KW
- C. Step 3 is 25 KW
- D. Step 4 is 25 KW
- E. Step 5 is 25 KW

Check to see that the voltage and frequency does not drop beyond acceptable limits under load.

WHEN OPERATING AT 240 THREE PHASE, THE LOAD BANK SHOULD NOT BE OPERATED MORE THAN THIRTY MINUTES AT MAXIMUM LOAD. THE LOAD BANK CAN OPERATED CONTINUOUS AT 70KW.

2-5 SHUTTING DOWN - Return the load and rate switches to the off position and, allow the load bank to cool down before turning the power unit off. Turn the power unit off and disconnect the power cable plug.

OPERATION

TESTING 480VAC THREE PHASE

2-1 SETTING UP THE LOAD BANK - Place the load bank in an area free from fuel, oil, or any other flammable substance. The load bank should be positioned so that any strong wind or air currents will flow with the air flow of the load bank.

2-2 APPLYING POWER - The load bank should be connected to the power unit to be tested with an output of 480VAC 3 phase, plug in the 120VAC power cord. Make sure that the main switch and the load switch is set to off before connecting the cable to the load bank. Use L1, L2, L3 and N, the blue and red plug, when testing 480VAC 3 phase circuits. Plug the power cable plug in to the load bank. Turn on the output of the power unit.

2-3 CHECKING THE POWER - check the following:

- A. The amber light, "A", "B", "C" should be on.
- B. The voltmeter should read 480VAC.
- C. The frequency meter should read approximately 60HZ.
- D. The ammeter should read 0A.

2-4 APPLYING THE LOAD - If the above steps checked OK, turn the main switch to 480VAC. The fans should start up and the airflow should be as indicated by the airflow arrow. Next turn on the load switch. Add the load desired with the rate switch.

- A. Step 1 is 12.5 KW
- B. Step 2 is 12.5 KW
- C. Step 3 is 25 KW
- D. Step 4 is 25 KW
- E. Step 5 is 25 KW

Check to see that the voltage and frequency does not drop beyond acceptable limits under load.

2-5 SHUTTING DOWN -Return the load and rate switches to the off position and allow the load bank to cool down before turning the power unit off. Turn the power unit off and disconnect the power cable plug.

PARTS INFORMATION

The following pages list the parts used in the load bank. All of the major parts are shown. Wire, screws, bolts, and small miscellaneous hardware are not listed. Parts that are purchased from a vendor will show a vendor name. These names refer to the vendor list is on page 8. Parts manufactured for or by EEPS will not show a vendor name.

A part number can be found by first locating the part on a drawing. After finding the part use the number to refer to the parts list on the opposite page. Each part will have a drawing number, EEPS part number, description and the number used for each load bank.

Parts should be ordered from the address below giving the machine model number, part number and the description.

Contact EEPS

Eagle Eye Power Solutions, LLC.

4230 N. Oakland Ave. Milwaukee, WI 53211

TEL: 1-877-805 EEPS (3377) FAX: 1-414-962-3660

www.eepowersolutions.com info@eepowersolutions.com

CONTROL PANEL PARTS

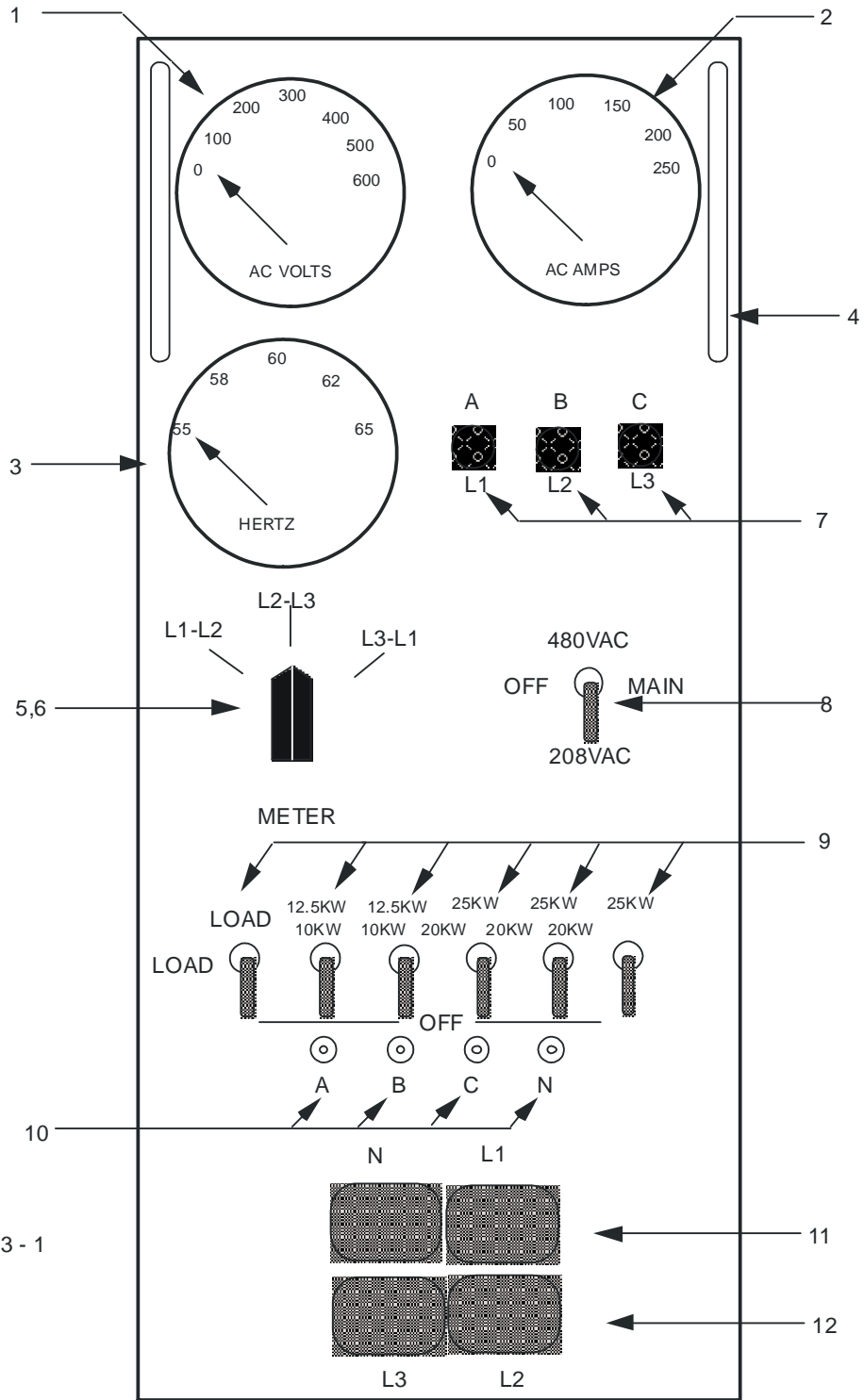

FIGURE 3 - 1

CONTROL PANEL PARTS
FIGURE 3-1

DRAWING NUMBER	PART NUMBER	DESCRIPTION VENDOR NO.	NUMBER USED
1	MR-62	0 - 600V VOLT METER	1
2	MR-64	0 - 100A AMMETER	1
3	MR-60	55-65 HERTZ FREQUENCY METER	1
4	HD-25	HANDLE	2
5	KN-10	POINTER KNOB	1
6	SW-48	ROTARY SWITCH 3 POSITION METER SWITCH (KRAUS & NAIMER CA11 A23-000 E SOG521)	1
7	LT-25	250VAC AMBER LIGHT	3
8	SW-01	TOGGLE SWITCH DPDT, DELAY	1
9	SW-22	TOGGLE SWITCH DPST	6
10	TP-10	TEST PIN	4
11	SB-13	SB CONNECTOR -2PIN-RED	1
12	SB-11	SB CONNECTOR-2PIN-BLUE	1

INTERIOR PARTS LAYOUT

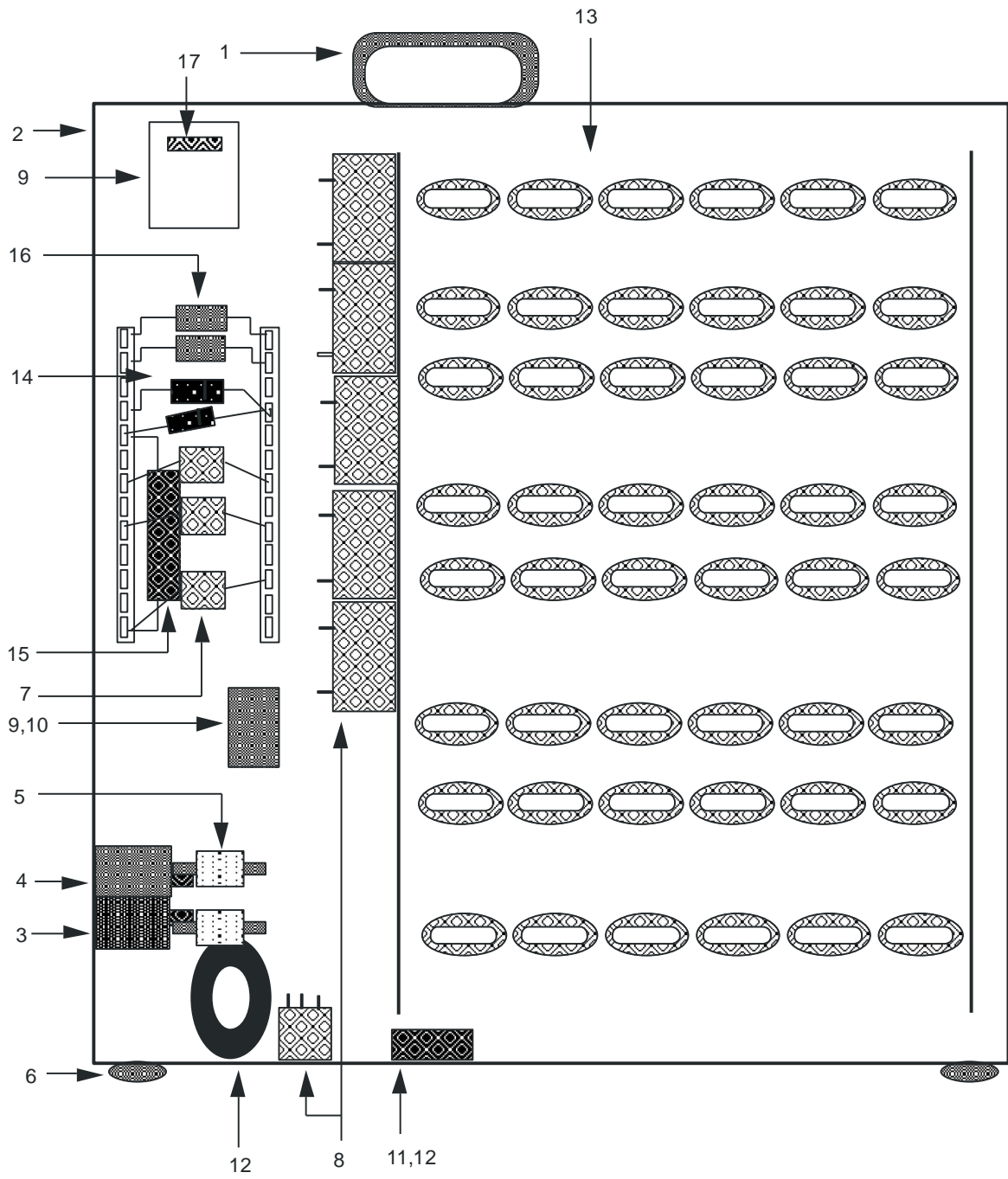

FIGURE 3 - 2

INTERIOR PARTS
FIGURE 3-2

DRAWING NUMBER	PART NUMBER	DESCRIPTION VENDOR NO.	NUMBER USED
1	HD-10	FOLDING HANDLE	1
2	BX-27	20" X 21" X 8" ALUM BOX	1
3	SB-11	SB CONNECTOR-2PIN-BLUE-175A	1
4	SB-13	SB CONNECTOR-2PIN-RED-175A	1
5	FS-62	250 FUSE, 600V	3
6	FT-10	GLIDES	8
7	RC-12	100Ω, 3W RESISTOR	2
8	RY-33	RELAY, 24VDC, 30A, DELTROL	16
9	PS-24	24 VOLT POWER SUPPLY	1
10	RY-21	RELAY, 120VAC, 2PDT, 10A MIDTEX 25862T200	1
11	SW-11	AIR FLOW SWITCH	1
12	CT-15	250:5 CURRENT TRANSFORMER	1
13	RM-25	25Ω RESISTOR	48
14	RD-19	200V, 5W ZENER DIODE	2
15	RC-14	12KΩ, 11W RESISTOR	2
16	RC-39	39KΩ, 2W RESISTOR	2
17	RC-25	560Ω RESISTOR 3W	1
*	GL-20	RESISTOR GRILL	1

FAN PANEL PARTS LAYOUT

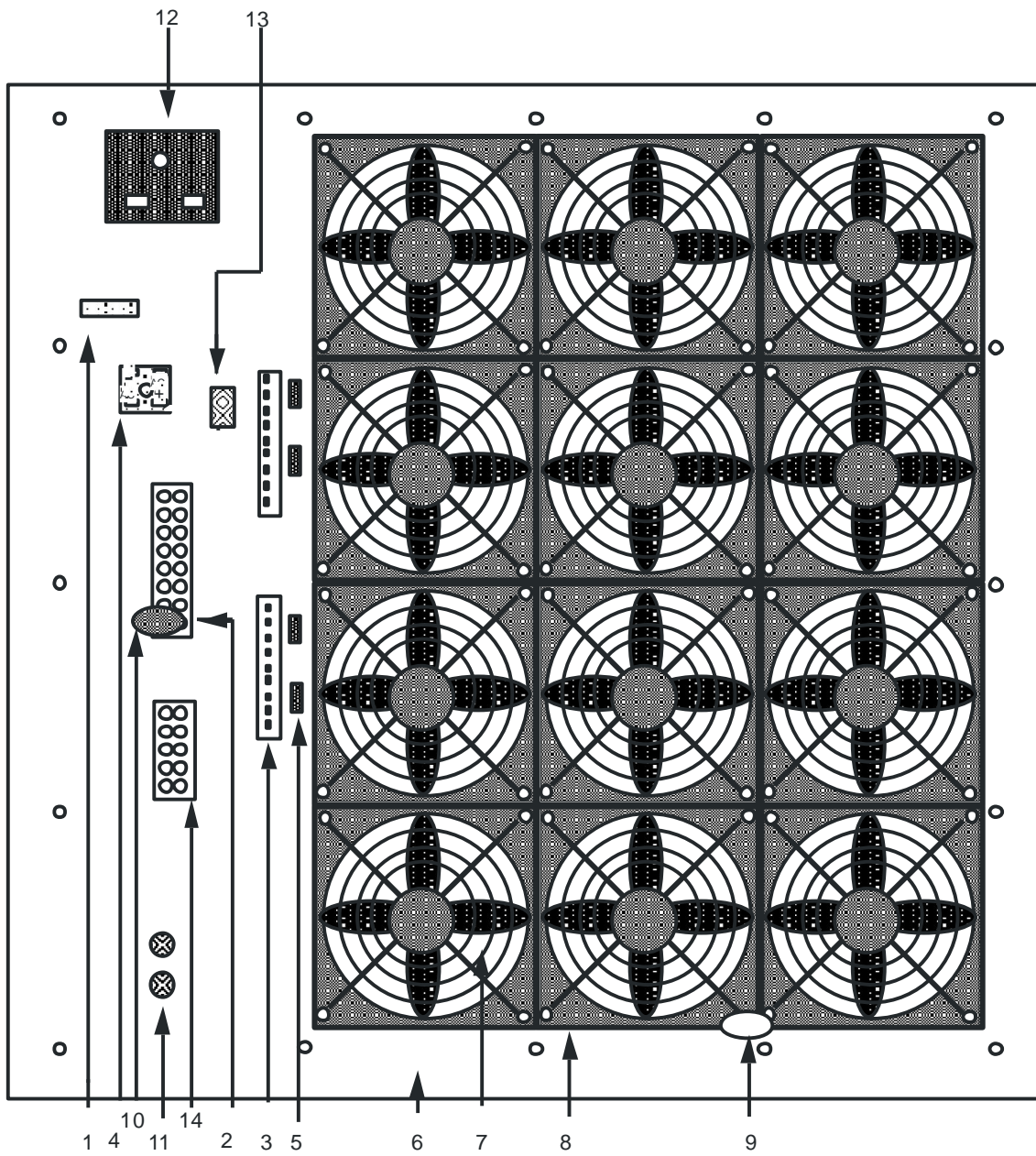

FIGURE 3 - 3

FAN PANEL PARTS
FIGURE 3-3

DRAWING NUMBER	PART NUMBER	DESCRIPTION VENDOR NO.	NUMBER USED
1	FS-11	FUSE 10A GLASS	1
2	TM-20	8 POSITION TERMINAL STRIP V-BEAU PRODUCTS (78008)	1
3	TM-09	TERMINAL STRIP 9 POS	2
4	RD-06	RECTIFIER 6A	1
5	CP-330	CAPICATOR, 330UF, 50VDC	4
6	FP-57	ALUM. FAN PANEL	1
7	GL-10	FAN GRILL CHROME V-MERRILL (B-22662)	12
8	FN-25	24VDC FAN EBM (W2G110-AK43-31)	12
9	TS-15	THERMAL SWITCH GEMLINE (L-155)	1
10	SW12	MERCURY SWITCH	1
11	RC-03	RESISTOR 3Ω 25 WATT	2
12	AC-01	120VAC PLUG CONNECTION	1
13	CP-33	330UF CAPICATOR 250VDC	1
14	TM-05	TERMINAL STRIP 5 POS	1

VENDOR LIST

The following is a list of vendors for parts shown in the parts list.

VENDOR

Anderson Power Products
145 Newton St.
Boston MA. 02135

Allied Electronics, Inc.
3425 Corporate Way, Suite A
Duluth, Ga. 30136

Bussmann Manufacturing
Distributed by Allied

Control Design Supply
1939-F Parker CT
Stone Mountain, GA. 30087

Cutler-Hammer
Distributed by Peerless

EBM Industries, Inc.
Distributed by Peerless

E.F. Johnson
Distributed by Peerless

Electric Supply Co.
433 Bishop St.
Atlanta, Ga. 30325

Gemline Products, Inc.
12472 Edison Way
Garden Grove, Ca. 92641

Merrill Manufacturing Corporation
236 South Genesee Street
Merrill, WI. 54452

Peerless Radio Corporation
3101 towercreek Pkwy, Suite 590
Atlanta, GA. 30339

Syrelec Electronics Corp.
Distributed by Control Design

Vemaline Products
333 Strawberry Field Rd.
Warwick, RI. 0288

GENERAL SERVICE

There is no regular maintenance required on the load bank. There are no adjustments inside the load bank. It should however be checked periodically for defective fans, burned out light bulbs, and defective meters.

To remove the fan panel, remove the screws around the outer edge.

The meters can be removed and replaced from the front panel.

The fan grills should be kept free of any trash.

Do not place any objects in the fan or resistor grill.

FAN REPLACEMENT

The following are steps to take to replace a defective fan.

1. Remove the screws holding the fan panel to the load bank.
2. Remove the three wires on the terminal strip that come from the load bank.
3. Drill out the rivets holding the fan (four on each side).
4. Lift up the fan and unplug it from the wire attached to the fan.
5. Plug a new fan into the same wire making sure that the fan is in the same position as the old fan.
6. Rivet the new fan back to the fan panel along with the fan grill.
6. Install the three wires back on the terminal strip. Place the fan panel back on the load bank.

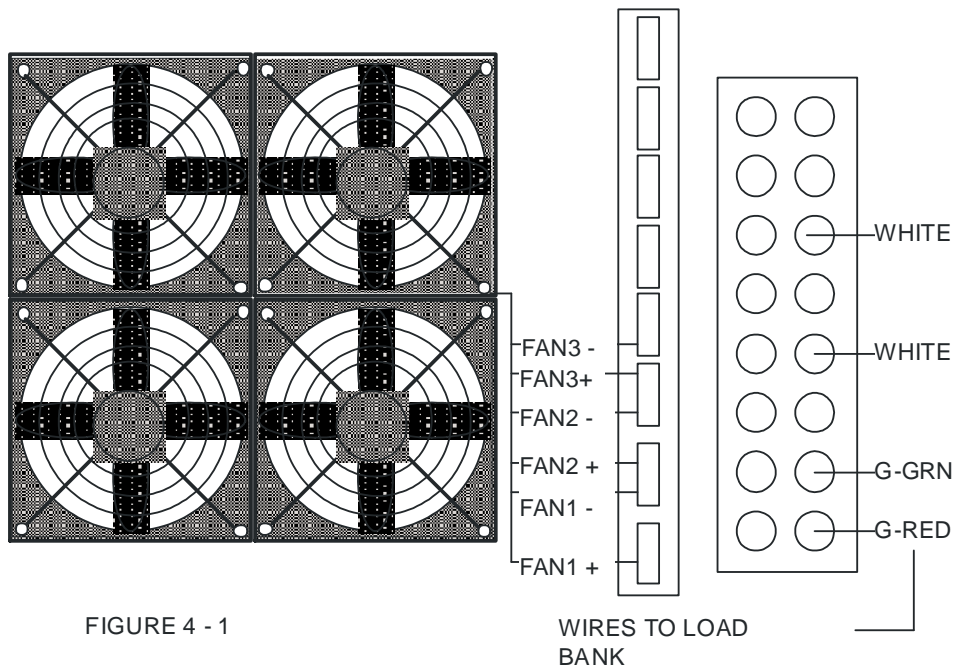

LB-60-80 INTERIOR WIRING

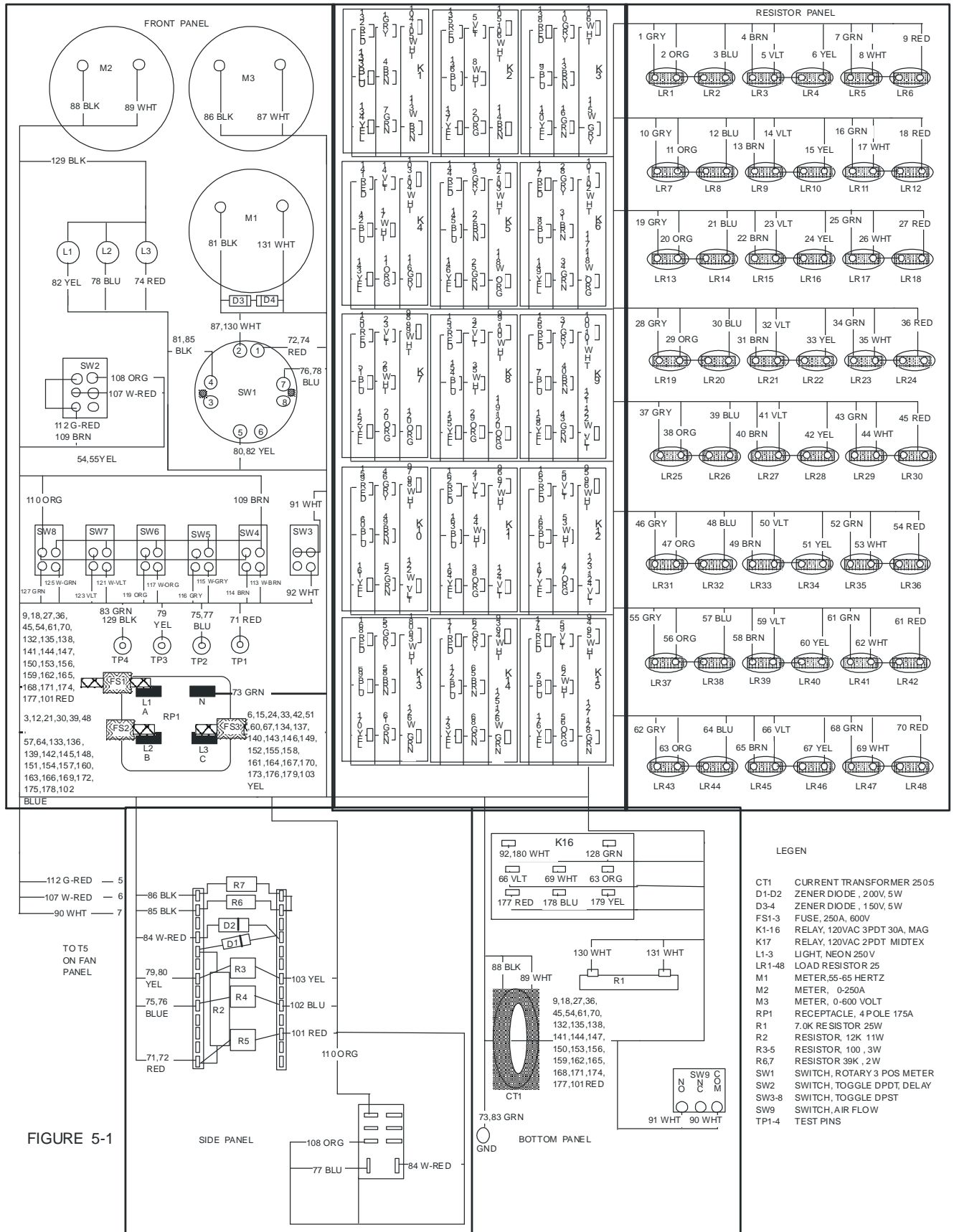

FIGURE 5-1

FAN PANEL WIRING

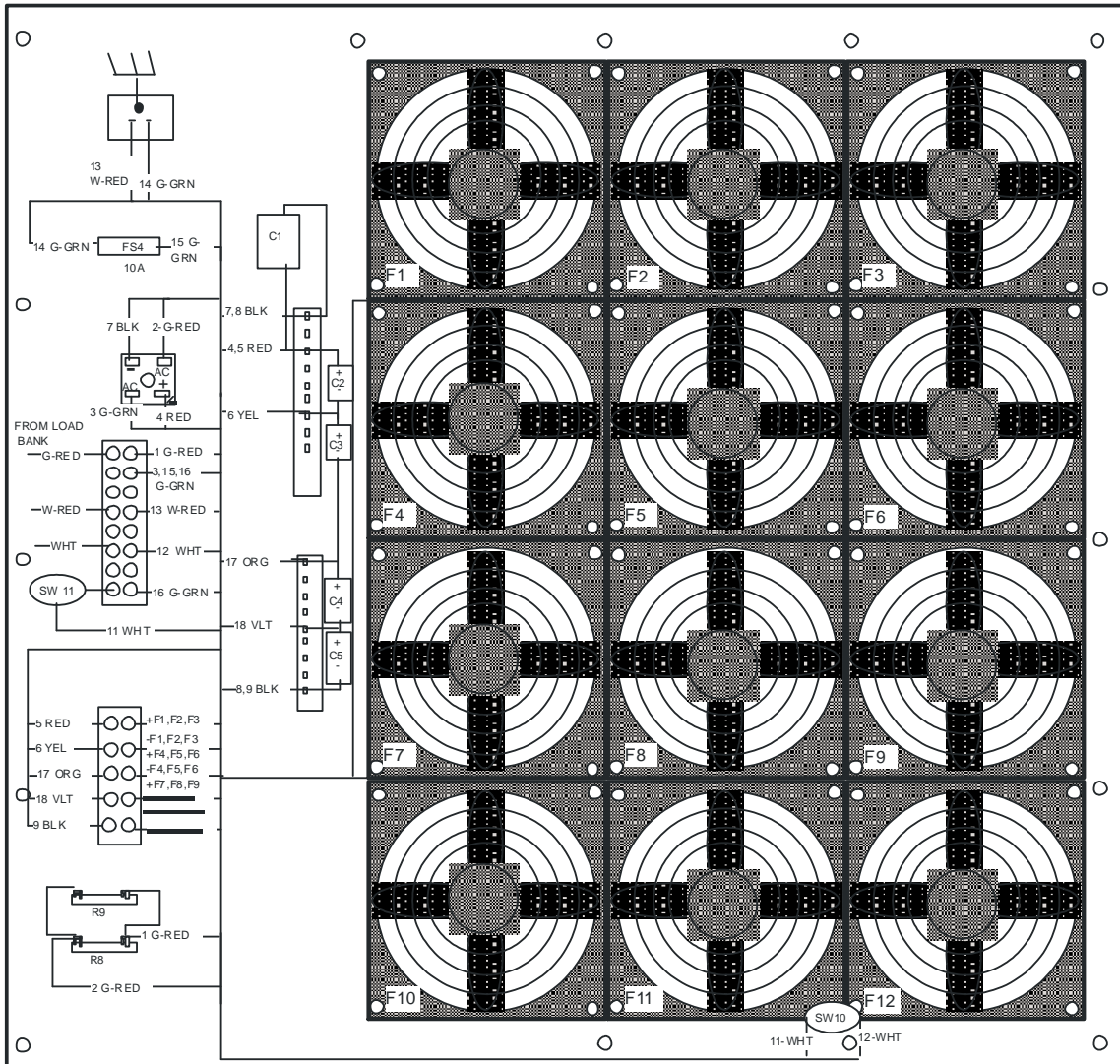

FIGURE 5 - 2

LB-60-80 SCHEMATIC

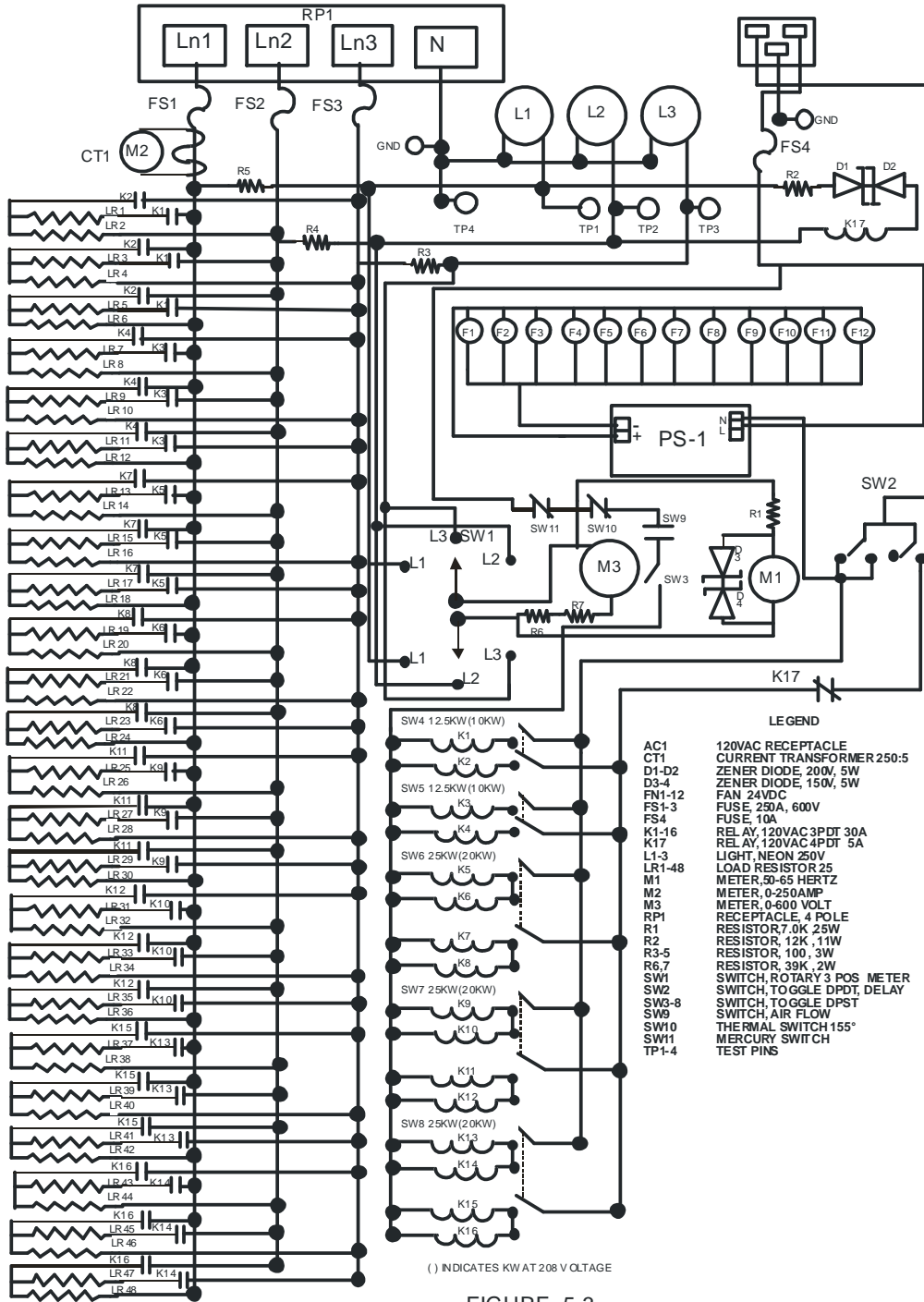

FIGURE 5-3

Contact EEPS

Eagle Eye Power Solutions, LLC.

4230 N. Oakland Ave. Milwaukee, WI 53211

TEL: 1-877-805 EEPS (3377) FAX: 1-414-962-3660

www.eepowersolutions.com info@eepowersolutions.com